



Art Bollard Sleeves

2nd Street Bridge and Extension (Shoal
Creek to West Avenue)

Art In Public Places Project

Artist Information Meeting

May 30, 2012



Art Bollard Sleeves

2nd Street Bridge and Extension (Shoal Creek to West Avenue)

Artist Information Meeting

Bowie Underpass
 Status: Design
 Construction: 2014 (estimated)
 Pedestrian and bicycle underpass of Union Pacific Railroad

Gables Park Plaza Ph I
 Status: Completed 2010
 294 Apartments
 8500 SF Commercial
<http://gables.com/find/apartment/1191-gables-park-plaza-austin-tx>

Gables Park Plaza Ph II
 Status: Proposed
 Construction: 2012
 313 Apartments
 15,000 SF Commercial

Sand Beach Improvements
 Status: Completed 2010
 Road realignment, district water quality and parkland improvements

Pfluger Bridge Extension
 Status: Completed 2011
 Extension of bicycle and pedestrian bridge over Cesar Chavez

Seaholm Power Plant Redevelopment
 Status: Design
 Construction: 2012 (estimated)
 298 Apartments
 43,000 SF Office
 84,000 SF Retail
 24,000 SF Event Center
<http://austingo.austintexas.gov/department/seaholm-power-plant-redevelopment>

Lower Shoal Creek Improvements
 Status: Design
 Construction: 2011 - 2015
 Various phases of trail improvement and bank stabilization in conjunction with adjacent projects – 5th Street to Lady Bird Lake

Energy Control Center Redevelopment
 Status: Master Development Agreement Approved
 Construction: 2014 (estimated)
 482 Condominium Units
 15,000 SF Commercial
<http://austingo.austintexas.gov/department/green-water-treatment-plant-redevelopment>

New Federal Courthouse
 Status: Construction
 Completion: 2012
 211,690 SF

Seaholm Substation Artwall
 Status: Design
 Construction: 2012
http://coapublish1.ci.austin.tx.us/aipp/downloads/seaholm_schematic_design2.pdf

Green Water Treatment Plant Redevelopment
 Status: Master Development Agreement Negotiation
 Construction: 2013 (estimated)
 695 Residential Units
 400 Hotel Rooms
 580,000 SF Office
 160,000 SF Retail
 Includes extension of W 2nd Street & Nueces through site
<http://austingo.austintexas.gov/department/green-water-treatment-plant-redevelopment>

2nd Street Bridge and extension to West Avenue
 Status: Design
 Construction: 2013 (estimated)
 In conjunction with New Central Library

New Central Library
 Status: Design
 Construction: 2013 (estimated)
 200,000 SF Central Library
<http://www.ci.austin.tx.us/library/newcentlib.htm>

Intake Structure Redevelopment
 Status: Feasibility Study
 Potential redevelopment of Seaholm Power Plant and Green Water Treatment Plant intake structures for park-oriented amenities

Seaholm District Update 2011



Art Bollard Sleeves

2nd Street Bridge and Extension (Shoal Creek to West Avenue)

Artist Information Meeting

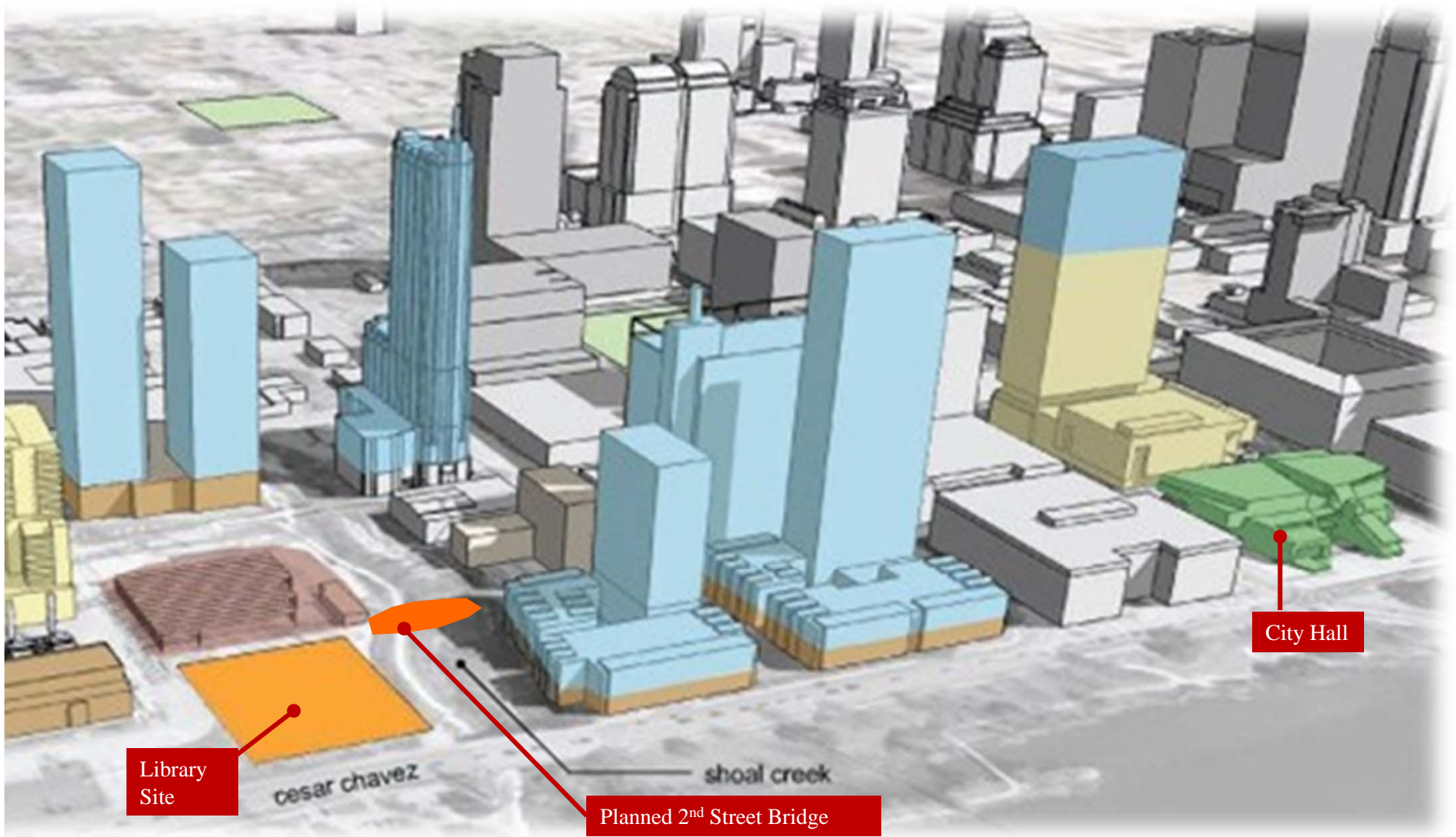



Art Bollard Sleeves

2nd Street Bridge and Extension (Shoal Creek to West Avenue)

Artist Information Meeting

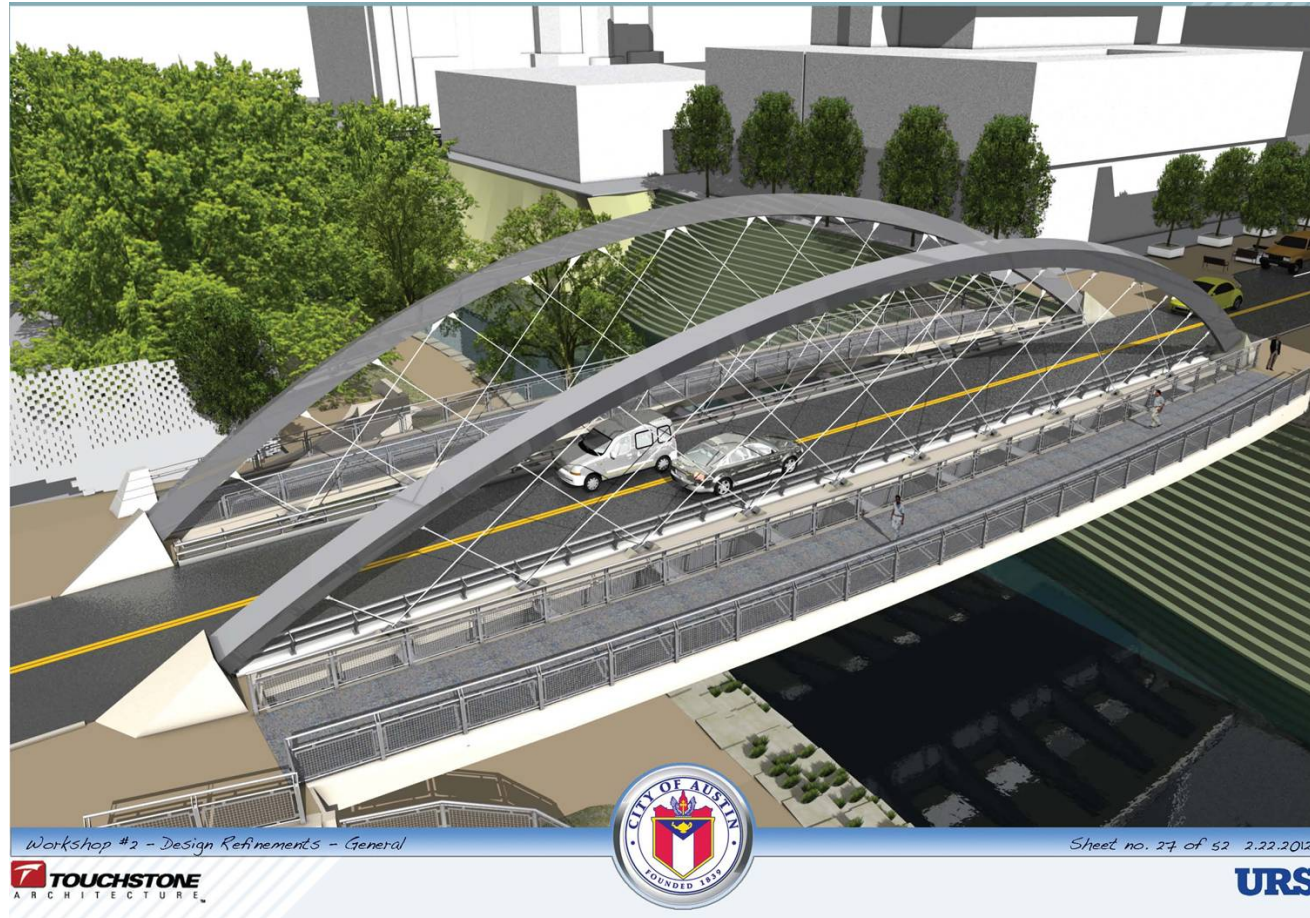

The City of Austin is constructing a new portion of 2nd Street, which will extend from Shoal Creek to proposed West Avenue (at the decommissioned Seaholm Power Plant).



Art Bollard Sleeves

2nd Street Bridge and Extension (Shoal Creek to West Avenue)

Artist Information Meeting - other AIPP Projects in the Area



Construction will include approximately 550 linear feet of new road and sidewalks, including an approximately 250' bridge over Shoal Creek.



Art Bollard Sleeves

2nd Street Bridge and Extension (Shoal Creek to West Avenue)

Artist Information Meeting - other AIPP Projects in the Area



2nd Street will be a *woonerf* (or festival streets) design concept with pedestrians and vehicles kept separated by bollards lining the street.



Art Bollard Sleeves

2nd Street Bridge and Extension (Shoal Creek to West Avenue)

Artist Information Meeting - other AIPP Projects in the Area



Amenities will include a bike porch, reading porches, a café, retail outlet of Recycled Reads bookstore, and opportunities to take classes and engage with the community.

The New Central Library, adjacent project to the AIPP site, will provide a high tech, cultural and information center for the area. It will be a major downtown destination; a state-of-the-art library that will inspire discovery.



Art Bollard Sleeves

2nd Street Bridge and Extension (Shoal Creek to West Avenue)

Artist Information Meeting - other AIPP Projects in the Area



Shoal Creek Trail runs under the planned 2nd Street Bridge and will be a major pedestrian and bike way through the Seaholm District.



Art Bollard Sleeves

2nd Street Bridge and Extension (Shoal Creek to West Avenue)

Artist Information Meeting - other AIPP Projects in the Area

Schedule for 2nd Street Bridge and Extension Project

Winter 2013 - Construction begins

Winter 2015 - Substantial Completion

Spring 2016 - Project opening and dedication

Schedule for New Central Library Project

January 2013 - Construction begins

Spring 2016 - Project opening and dedication

- All schedules subject to change -

Site Plan

2nd Street Bridge and Extension(Shoal Creek to West Avenue)

**Historic
Seaholm
Power Plant**

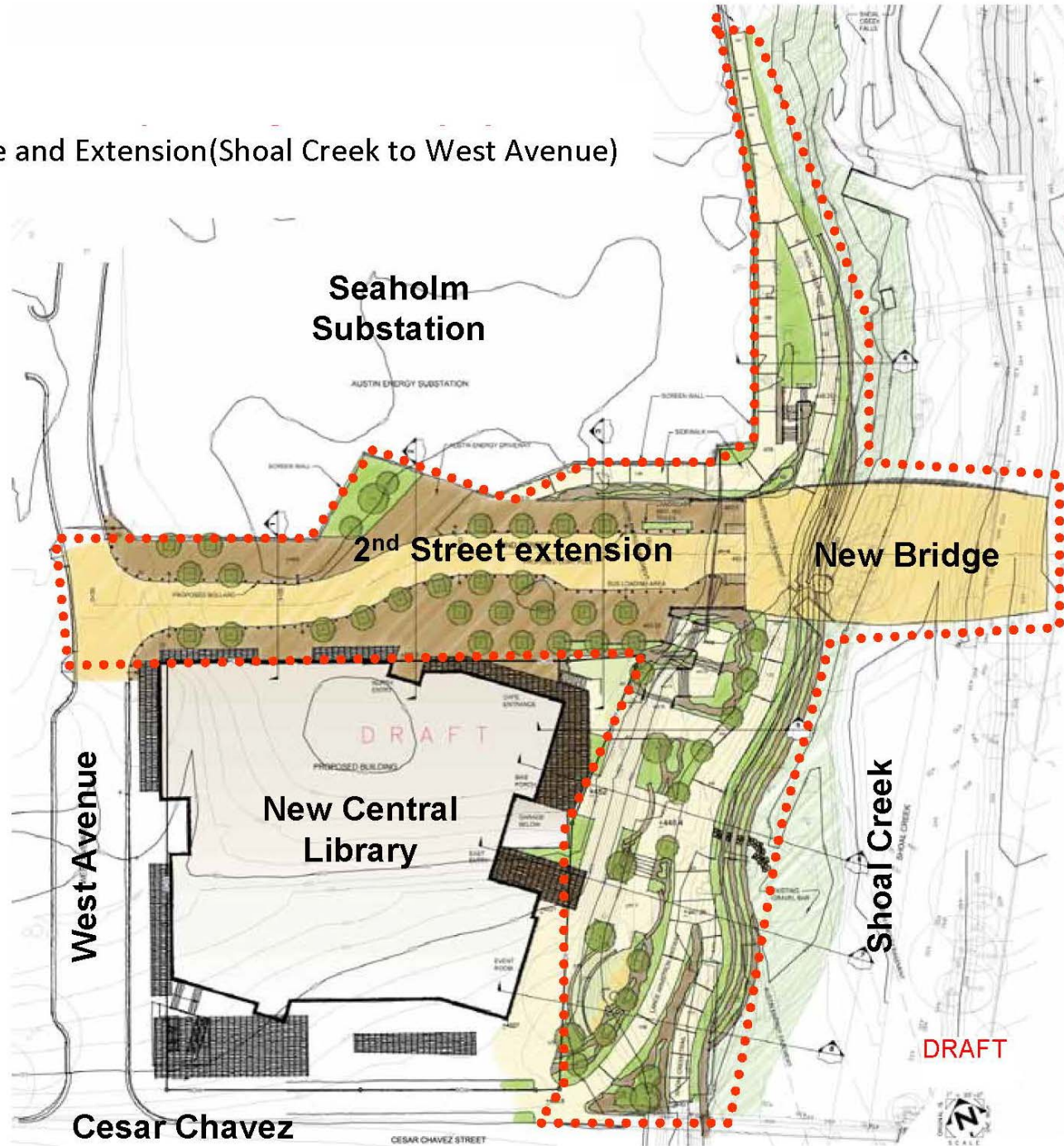

DRAFT





Art Bollard Sleeves

2nd Street Bridge and Extension (Shoal Creek to West Avenue)

Artist Information Meeting – Site Plan

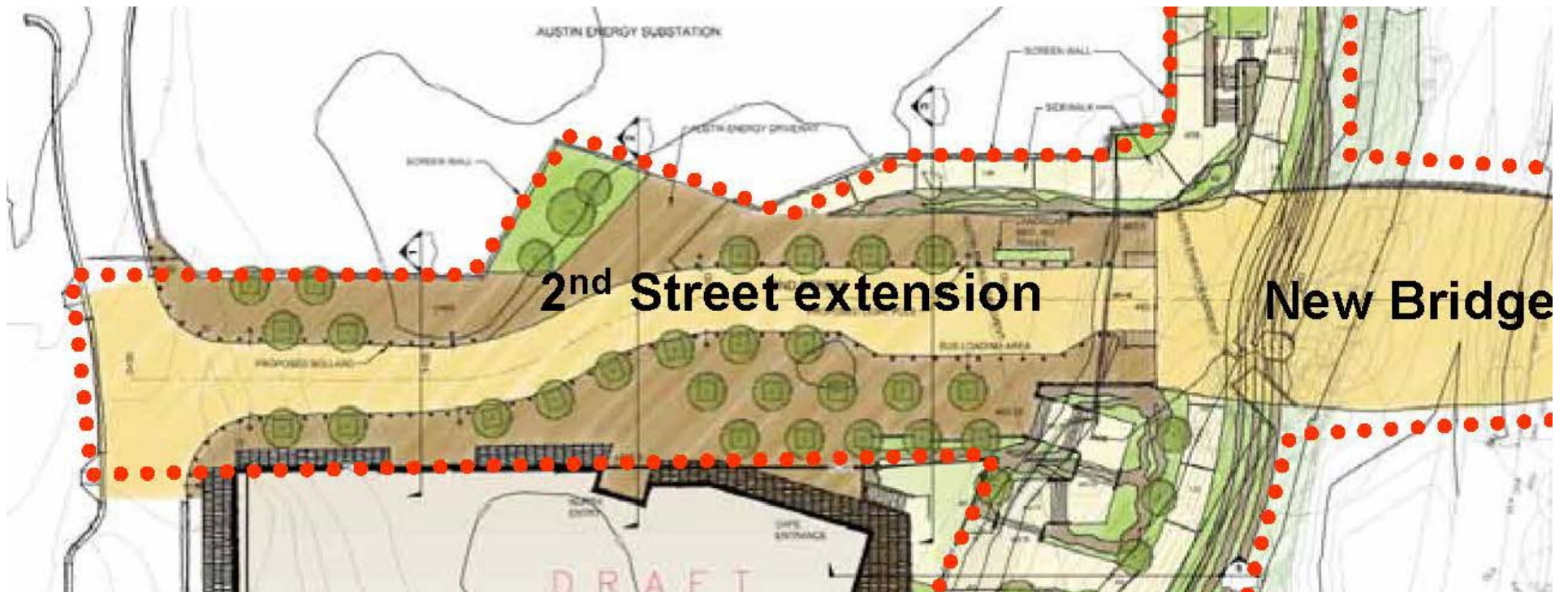

Bollards will likely be placed 7' 4" apart along both sides of 2nd Street Extension. There may be as many as 70- 80 bollards.

It is expected that **the art sleeves will engage 12 – 20 of them**; locations to be determined through collaboration between artist and design team.

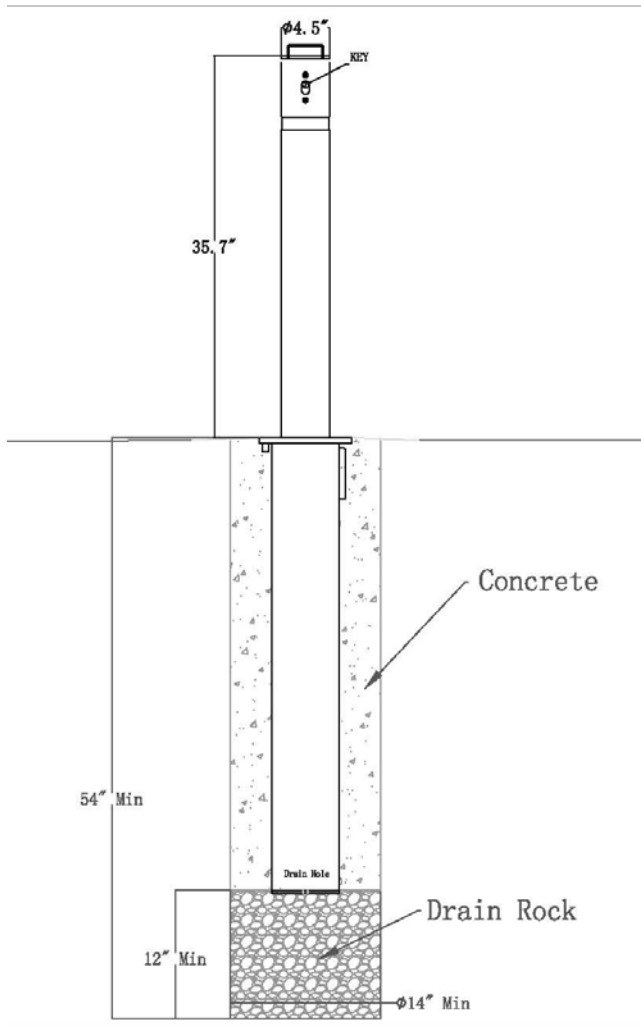

This is the bollard being considered for this project. This selection is subject to change.







Wall Street, Asheville, NC



Netherlands (unknown city)





Art Bollard Sleeves

2nd Street Bridge and Extension (Shoal Creek to West Avenue)

Artist Information Meeting

The Art in Public Places program seeks to commission works of art of redeeming quality that advance public understanding of visual art and enhance the aesthetic quality of public places.

The artwork is intended to serve as a lively and engaging piece for the community of Austin.

The exact scope and location of the artwork will be based upon the artist's vision and discussions between the artist and the design team.

Due to the challenges for maintenance of the artwork, only artwork of substantial durability and low maintenance needs will be considered.

The goal of this specific public art project is to select an artist who will create a work that will:

- be a unique work of contemporary art for the public;
- be responsive to site opportunities, conditions and constraints;
- enhance the experience of being a pedestrian, cyclist or driver on 2nd Street;
- be easily maintained and safe.



Art Bollard Sleeves

2nd Street Bridge and Extension (Shoal Creek to West Avenue)

Artist Information Meeting – The art bollard sleeves are required to meet these minimum criteria:

- Art bollard sleeves will be a minimum of 42" tall. Sleeves will be a minimum diameter of 6-8" and a maximum diameter of 18".
- Art bollard sleeves will be securable, to prevent theft.
- Art bollard sleeves will be reproducible, so the City is able to install any number of bollard sleeves in the Seaholm District or throughout the City. At this juncture, it is expected that this budget will provide between 12 to 20 bollard sleeves for 2nd Street.
- Art bollard sleeves must be produced with durable material(s), able to withstand the elements and urban environment without degrading, for a minimum of 15 years.
- Art bollard sleeves may incorporate light, as long as it will not interfere with drivers' or cyclists' ability to see.
- For the purpose of this Request for Proposals, the art bollard sleeves should be able to withstand a crash of 5 mph by a 5000 lb vehicle without requiring repair; the selected artist will work with the Engineering Services Division of the City of Austin during design to address required durability.
- Art bollard sleeves are required to fit snugly, without wiggling or moving, over a standard 6" or 8" wide diameter steel concrete filled pipe provided by the City.



Art Bollard Sleeves

2nd Street Bridge and Extension (Shoal Creek to West Avenue)
Artist Information Meeting

Budget

A maximum amount of \$65,000 is available for this public art project. The selected artist(s) will be responsible for all aspects of design, fabrication and construction including design and fees, transportation, and insurance.

- City of Austin Public Works will provide engineering support for fabrication and installation of the art bollard sleeves.
- Installation costs, including foundation and city fees, will be by City of Austin.

Artist Eligibility

Professional visual artists at least 18 years of age legally residing within 50 miles of Austin are eligible to apply.

Full-time, permanent City of Austin employees, all employees of the Economic Growth & Redevelopment Services Office and the sponsor department (Public Works), including their employees, project consultants, and sub-consultants are ineligible to apply.



Art Bollard Sleeves

2nd Street Bridge and Extension (Shoal Creek to West Avenue)

Artist Information Meeting

- Artistic merit of body of work
- Strong conceptual skills with innovative and effective approaches demonstrated in other creative projects
- Ability to design artwork that is sensitive to social, environmental, historical, and/or other relevant contexts
- Ability to translate artistic concepts into materials that are appropriate for public space, taking into consideration maintenance, safety, and longevity
- Potential for work to enrich and diversify the City of Austin Art in Public Places Collection
- Completeness of application
- Ability and willingness to collaborate with City staff, design and engineering professionals, stakeholders, and contractors
- Probability of successful execution and completion of project
- Appropriateness of qualifications for the project
- Effective communication and organizational skills
- Demonstrated successful projects of a similar scope
- Ability to effectively engage with other design professionals, community stakeholders and user groups



Art Bollard Sleeves

2nd Street Bridge and Extension (Shoal Creek to West Avenue)
Artist Information Meeting

Deadline: 5 p.m. on Thursday, June 14, 2012.

Late applications are not accepted. *Don't wait until the last minute to start your application!*

Applicants must submit all materials through the ASAPP! online application system, at https://www.austintexas.gov/aipp/apply/dsp_artist_calls.cfm

Complete a registry profile on ASAPP!

Select a minimum of 10 images (maximum of 15) from your registry profile to apply for the call. Artist teams must have each team member's work represented within the 10 - 15 images selected for review.

Letter of Interest (2000 character limit): Briefly describe your specific interest in the 2nd Street Bridge/Extension Art in Public Places Project and explain why your qualifications are a good fit for this project. Please keep in mind the project's "Public Art Intent and Goals."



Art Bollard Sleeves

2nd Street Bridge and Extension (Shoal Creek to West Avenue)
Artist Information Meeting

| | |
|------------------------------|--|
| May 17, 2012 | RFQ released |
| May 30, 2012, 5:30 p.m. | Artist Information Meeting |
| June 14, 2012 at 5 pm | Deadline for submission of Proposals |
| July 2012 | Approval of Selected Artist and Alternate |
| August 2012 | Council authorizes contract negotiation |
| Sept. – Oct. 2012 | Artist works through design with Engineering Services. |
| Spring 2016 | 2 nd Street Bridge and Extension Project Opening and Dedication |



Art Bollard Sleeves

2nd Street Bridge and Extension (Shoal Creek to West Avenue)

Artist Information Meeting

Questions?