



Residential Technical Review Handout For Informational Purposes Only

DevelopmentATX.com | Phone: 311 (or 512-974-2000 outside Austin)
For submittal and fee information, see austintexas.gov/digitaldevelopment

2015 International Residential Code –

<https://codes.iccsafe.org/public/document/toc/553/>

Local Amendments -

https://library.municode.com/tx/austin/codes/land_development_code?nodeId=TIT25LADE_CH25-12TECO_ART11RECO

Updated 05/06/2021

✓ EGRESS REQUIREMENTS

Emergency escape and rescue required

Basements, habitable attics, and every sleeping room shall have at least one operable emergency escape and rescue opening with a window sill height of not more than 44 inches above finished floor (AFF). *Reference* R310.1 and R310.2.2.

Minimum opening area

All emergency escape and rescue openings shall have a minimum net clear opening of 5.7 sq. ft. *Reference* R310.2.1 **Exception:** *Grade floor* or below grade openings (sill \leq 44" above or below finished ground level) shall have a minimum net clear opening of 5 sq. ft.

Minimum opening height

The minimum net clear opening height shall be not less than 24 inches. *Reference* R310.2.1

Minimum opening width

The minimum net clear opening width shall be not less than 20 inches. *Reference* R310.2.1

Door type and size

The required exit door shall be a single-hinged door not less than 32" clear in width and 78" inches clear in Height (Typically must be a 3'0" wide x 6'8" high door to meet requirements). *Reference* R311.2

Retrofit Windows

Requirements for Retrofit Windows, *reference* local amendment AJ102.4.3 Emergency Escape and Rescue Openings.

Floors and landings at exterior doors

There shall be a landing or floor on each side of each exterior door with a minimum width of the door served. These landings at the required egress door will not be more than 1 ½" inches lower than the top of the threshold. Exterior landings may not be more than 7 ¾" below the top of the threshold provided the door does not swing over the landing. *Reference* R311.3.1

Bedroom Window Egress

The second exit required in a bedroom is usually a window. The dimensions of the openings are to ensure the residents an escape route, but equally important, they are designed to allow a firefighter with a backpack to enter. The opening must be at least 24" high and at least 20" wide, with a net area at least 5.7sq.ft., per T15. The window sill must not be higher than 44" from the floor.

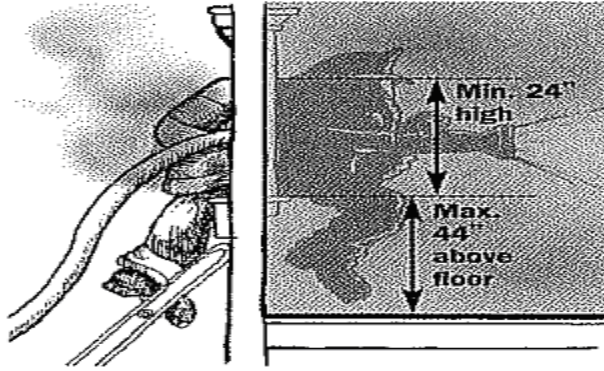

✓ MINIMUM ROOM AREAS/CEILING HEIGHT

Minimum area

Habitable rooms shall have a floor area of not less than 70 sq. ft. *Reference R304.1*

Exception: Kitchens

Minimum dimensions

Habitable rooms shall not be less than 7 feet in any horizontal dimension. *Reference R304.2*

Exception: Kitchens

Height effect on room area

Portions of a room with a sloping ceiling measuring <5' or furred ceiling measuring <7' above finished floor (AFF) shall not be considered as contributing to the minimum required habitable area for that room. *Reference R304.3*

Minimum height

Habitable space, hallways, and portions of basements containing these spaces shall have a height of not less than 7 feet AFF.

Bathrooms, toilet rooms and laundry rooms shall have a ceiling height of 6'-8". *Reference R305.1*

Exception: Items 1-3 listed on page 57 of 2015 IRC & R305.1.1 Basements.

✓ SMOKE ALARMS REQUIREMENTS

Listings

Smoke alarms shall be listed in accordance with UL 217. *Reference R314.1.1*

Location

Smoke alarms shall be installed in the following locations: **Each sleeping room, outside each sleeping area** in the immediate vicinity of the bedrooms, **on each additional story** of the dwelling, and not less than 3 feet from a door to a bathroom with tub or shower except when this requirement would prevent the installation of a smoke alarm in a required location. **Note:** When more than one smoke alarm is required to be installed, the devices shall be hard-wired and interconnected, with battery back-up. Interconnection not required when listed wireless alarms are installed and they all sound upon activation of one. *Reference R314.3 and R314.4*

Alterations, repairs and additions

When alterations, repairs or additions requiring a permit occur, or when one or more sleeping rooms are added or created in existing dwellings, the individual dwelling unit shall be equipped with smoke alarms located as required for new dwellings; the smoke alarms shall be interconnected and hard wired. **Exceptions:** Exterior work such as roofing or siding, replacement or addition of windows and doors, addition of a porch or deck, and mechanical and plumbing work are exempted from providing smoke alarms as required for new construction. Interconnection and hard wiring of existing areas is not required unless there is existing access through attic, basement or crawl space, or access is possible as a result of work being done. *Reference R314.2.2, R314.4, and R314.6*

CARBON MONOXIDE ALARMS REQUIREMENTS

Listings

Carbon monoxide alarms shall be listed in accordance with UL 2034. *Reference* R315.1.1

Where Required

For new construction, carbon monoxide alarms shall be installed in dwelling units within which fuel-fired appliances are installed and in dwelling units that have attached garages with a door that connects the garage with the residence. Carbon monoxide alarms shall be hard wired with battery backup, except for CO alarms in buildings without commercial power which can be battery operated.

Reference R315.2 and R315.5

Locations

For new construction, an approved carbon monoxide alarm shall be installed outside of each separate sleeping area in the immediate vicinity of the bedrooms. Required inside bedrooms with fuel burning appliances within the bedroom or attached bathroom.

Reference R315.3

Alteration, repairs and additions

Where work requiring a permit occurs in existing dwellings that have attached garages or in existing dwellings within which fuel-fired appliances exist, carbon monoxide alarms shall be installed as stated above. **Exceptions:** Exterior work such as roofing or siding, replacement or addition of windows and doors, addition of a porch or deck, and mechanical and plumbing work are exempted from the above. Carbon monoxide alarms for alterations, repairs and additions can be battery operated. *Reference* R315.2.2 and R315.5

✓ SAFETY GLAZING

Hazardous locations requiring safety glazing *Reference* R308.4

The following locations/uses (but not limited to) require tempered safety glass:

- Panels on doors, except for glazed openings through which a 3" dia. sphere cannot pass, or decorative glazing
- Panels adjacent to door that are less than 60" above walking surface provided that panel is in the same plane of the door in a closed position and within 24 inches of either side of the door or where panel is perpendicular and within 24" of the hinge side of an in-swing door.
- Panels in windows where individual panel exceeds 9sf, and bottom of glazing is less than 18" above floor, and top edge is over 36" above floor, and walking surface is within 36" of glazing measured horizontally and in straight line.
- Guards and railings
- Walls, enclosures or fences containing or facing hot tubs, spas, whirlpools, saunas, steam rooms, bathtubs, showers and swimming pools where bottom of edge of glazing is less than 60" from walking surface. **Exception:** Glazing more than 60" from edge of bathtub, hot tub, spa, whirlpool or pool, shower, sauna, or steam room.
- Panels less than 36" above a stair landing and within 60" from landing measured horizontally
- Skylights and Sloped Glazing

Note: The above is a condensed list of the most common safety glazing situations. There are many variables and exceptions not listed above which can be found on pages 55-58 of 2015 IRC

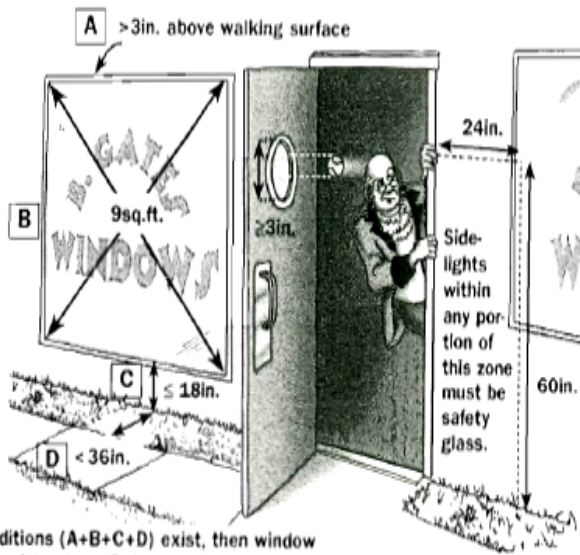

If all conditions (A+B+C+D) exist, then window must be safety glass. Safety glazing would also be req'd if within 2ft. of the door frame.



Safety glazing is required when a walk-through hazard exists, defined as meeting ALL of the following:

- Exposed area of glazing >9sq ft. +
- Bottom edge <18in above floor or ground +
- Top edge >36in above floor or ground +
- Within 36in horizontal of walking surface
- Exception: Min 1½in high protective guard installed 34-38in above floor

✓ TOILET, BATH AND SHOWER SPACES

Space required

Fixtures shall be spaced as per figure below. Reference R307 Figure 307.1. and 2015 UPC 402.5

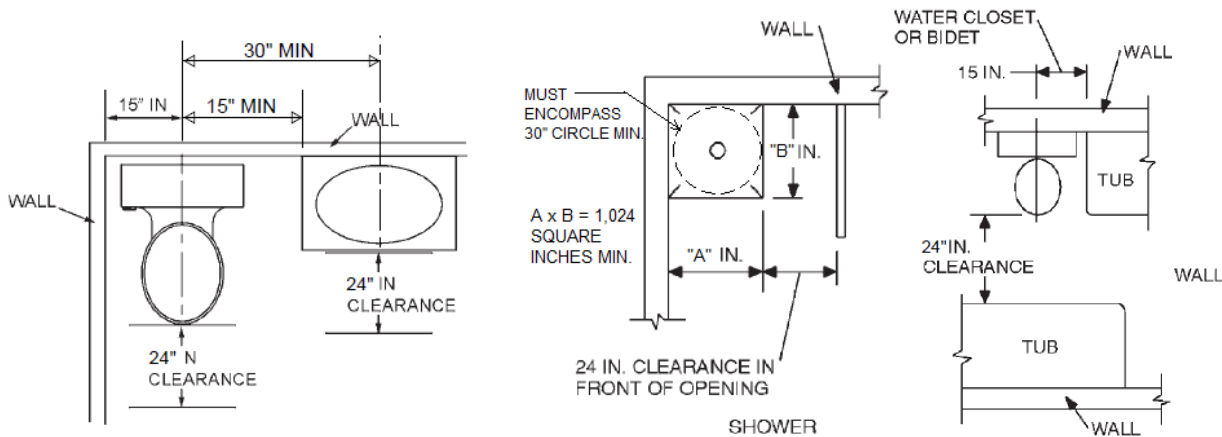

✓ **HANDRAILS/GUARDRAILS**

Handrails

Provided on at least one side of each continuous run of treads or flight with four or more risers. *Reference 311.7.8*

Height

Measured vertically from the sloped plane of stairs or ramp shall not be less than 34 inches and not more than 38 inches. *Reference 311.7.8.1*

Continuity

Shall be continuous for the full length of the flight, from directly above the top riser to directly above the lowest riser and shall be returned. *Reference R311.7.8.2*

Handrail Height

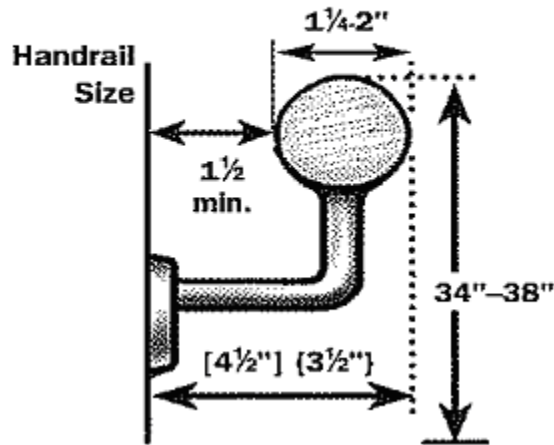
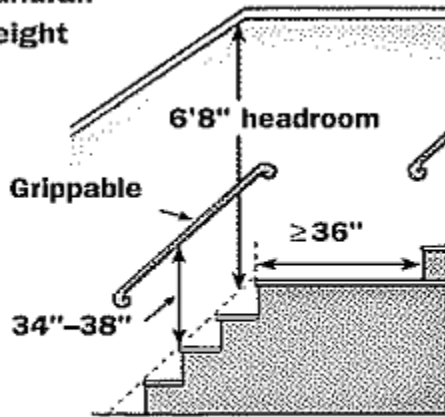

Guardrails

Porches, balconies, ramps or raised floor surfaces located more than 30 inches above floor or grade below at any point within 36" horizontally to the edge shall have guards not less than 36 inches in height with a maximum 4 inch opening. *Reference 312.1*

Guardrails

Guardrail req'd when deck surface to ground >30"

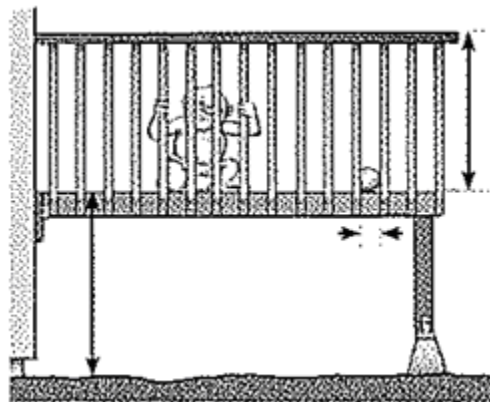

Min. height: 36" single family dwelling

Max. opening such that a 4" sphere cannot pass through

✓ STAIRWAYS

Width

Shall be not less than 36 inches in clear width above handrail height and below headroom height. Handrails shall not project more than 4.5 inches on either side and minimum clear width shall not be less than 31.5 inches where handrail is provided on one side and 27 inches where handrails are provided on both sides. *Reference R311.7.1*

Headroom

Minimum headroom in all parts of the stairway shall not be less than 6 feet 8 inches. *Reference R311.7.2*

Vertical Rise

A flight of stairs shall not have a vertical rise larger than 12'-3" (147 inches) between floor levels or landings. *Reference R311.7.3*

Riser height

Maximum riser height shall be 7 ¾ inches. The greatest riser height within any flight of stairs shall not exceed the smallest by more than 3/8 inch. *Reference 311.7.5. 1*

Tread depth

Minimum tread depth shall be 10 inches. The greatest tread depth within any flight of stairs shall not exceed the smallest by more than 3/8 inch. *Reference 311.7.5. 2*

Landings

There shall be a floor or landing at the top and bottom of each stairway. The width of each landing shall not be less than the width of the stairway served and shall have a minimum dimension of 36 inches in the direction of travel. **Exception:** A floor or landing is not required at the top of an interior flight of stairs, including the stairs in an enclosed garage, provided that a door does not swing over the stair. *Reference 311.7.6*

Winding Stairs

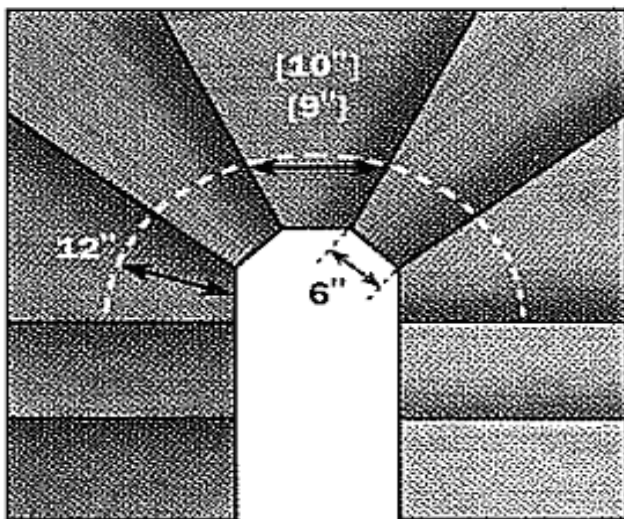

Stair Profile

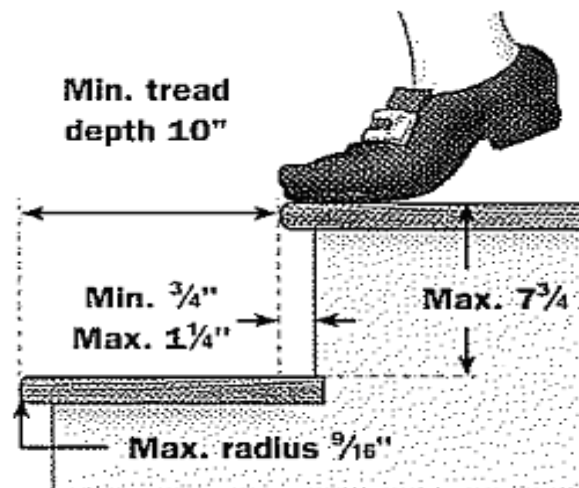

✓ EXTERIOR WALLS

Exterior wall location *References* IRC Table R302.1(1) and R302.1 Local Amendments

Construction, projections, openings and penetrations of exterior walls of dwellings and accessory buildings shall comply with table below. These provisions shall not apply to walls, projections, openings or penetrations in walls that are perpendicular to the line used to determine fire separation distance.

Exceptions: Detached tool sheds and storage sheds, playhouses and similar structures exempted from permits are not required to provide wall protection based on location on the lot. Projections beyond the exterior wall shall not extend over the lot line. 2. Detached garages accessory to a dwelling located within 2 feet (610 mm) of a lot line are permitted to have roof eave projections not exceeding 4 inches (102 mm). 3. Foundation vents installed in compliance with this code are permitted.

| EXTERIOR WALL ELEMENT | | MINIMUM FIRE-RESISTANCE RATING | MINIMUM FIRE SEPARATION DISTANCE |
|-----------------------|-----------------------------|--|----------------------------------|
| Walls | (Fire-resistance rated) | 1 hour-tested in accordance with ASTM E 119 or UL 263 with exposure <i>from</i> both sides | < 5 feet |
| | (Not fire-resistance rated) | 0 hours | ≥ 5 feet |
| Projections | Not allowed | N/A | < 2 feet |
| | (Fire-resistance rated) | 1 hour on the underside ^{a, b} | ≥ 2 feet to < 5 feet |
| | (Not fire-resistance rated) | 0 hours | ≥ 5 feet |
| Openings in walls | Not allowed | N/A | < 3 feet |
| | 25% maximum of wall area | 0 hours | 3 feet |
| | Unlimited | 0 hours | 5 feet |
| Penetrations | All | Comply with Section R302.4 | < 3 feet |
| | | None required | 3 feet |

^a Roof eave fire-resistance shall be permitted to be reduced to 0 hours on the underside of eave if fireblocking is provided from the wall top plate to underside of roof sheathing

^b Roof eave fire-resistance rating shall be permitted to be reduced to 0 hours on the underside of eave provided gable vent openings are not installed

✓ VISITABILITY

Visitability applies to new dwellings units subject to the IRC with habitable space in the first floor.

Detailed plans must be prepared by a Texas-Registered Architect or Certified Building Designer holding a National Council of Building Designers Certification seal. Drawings and notes must be provided specific to project.

- Exterior route originating from garage, driveway, public street or public sidewalk to visitable entrance.
- No-step visitable entrance 32" clear (36" door) with beveled threshold 1/2" or less and landing.
- 32" clear accessible route from entrance through living/dining/kitchen to visitable bathroom.
- Water closet/bathroom located on the first floor shall have a net clear opening of at least 30 inches (32" door) and 2x6 blocking @ 34" height from finished floor for grab bars. Door swings shall not impede the 30" x 30" clear floor space within the visitable bathroom.
- Light switches & environmental controls no higher than 48" and outlets no lower than 15" above the floor.

Waiver of Exterior Visitable Route A waiver for exterior route can be requested with permit application for:

1. Lots with 10% or greater slope prior to development; or
2. Properties for which compliance cannot be achieved without the use of switchbacks.

*S.M.A.R.T. Housing waivers must be approved by the Housing and Planning Department.

Reference R320 local amendment <http://www.austintexas.gov/edims/document.cfm?id=205386>.

Note: Refer to **Building Criteria Manual section 4.4.7 Visitability** for additional information:

https://library.municode.com/tx/austin/codes/building_criteria_manual?nodeId=S4RECO_4.4.0RESURE_4.4.7VI

Criteria for Structural Plans

Suspended Foundations:

- Pier/Footing locations/dimensions
- Pier/footing sizes and depth below grade
- Footing details (materials, reinforcing, etc.)
- Joist/beam layout (size and spacing)
- Details for anchorage of structure to foundation
- Foundation requirements at braced wall panels
- Connection to existing foundation where applicable

Slab-on-grade Foundations:

- Slab layout (beam locations, changes in slab elevation, slab openings)
- Beam sizes (width and depth)
- Concrete compressive strength
- Reinforcing details
- Details for anchorage of structure to foundation
- Foundation requirements at braced wall panels
- Connection to existing foundation where applicable

Footings (for decks, pergolas, carports, etc.):

- Footing locations/dimensions
- Footing sizes and depth below grade
- Footing details (materials, reinforcing, etc.)
- Connection details for superstructure to foundation

Wood Framed Walls:

- Stud spacing/ wood grade
- Headers – size/span/material type
- Foundation/floor/ceiling connection details
- Anchor requirements to foundation

Wood Framed Floors:

- Live loads supported
- Joist sizes
- Joist layout/spacing
- Intermediate girder size and location
- Floor sheathing information (type, thickness)

Wood Framed Roofs:

- Live load supported
- Ceiling joist size/layout/spacing
- Rafter size/layout/spacing
- Ridge boards
- Roof sheathing information (type, thickness)
- Collar ties
- Rafter ties

Trusses/I-joists:

- Truss layout and spacing
- Support structure framing (headers, beams, walls, columns)
- Truss package due at field inspections

Wind Bracing Plans:

- Braced wall lines layout
- Braced wall methods used
- Braced wall panel locations
- Fasteners/nail pattern
- Details for methods used

Structural design must meet the prescriptive requirements of the 2015 International Residential Code; otherwise a Texas-licensed engineer or architect must provide and seal the structural drawings. A Texas-licensed engineer is required for foundations on

Structural Verifications

A Structural Verification Report, completed by a Texas Registered Architect or Engineer, can be submitted in lieu of structural drawing requirements for the following conditions:

- 1) Conversion of a carport with an existing foundation, open on no more than 2 sides, to a single-story habitable space.
- 2) Projects eligible for a Remodel/Repair permit where no additions to the proposed building are proposed
- 3) Change of use with remodel work only where no additions to the building are proposed
- 4) Verification of existing foundations less than 10 years in age
- 5) Verification of existing framing and wall bracing for structures between 5 to 10 years of age
- 6) As required by the reviewer to complete a review for technical code compliance

This verification should include at the minimum:

- 1) Date of the site visit
- 2) Areas of the property observed
- 3) Detailed foundation and framing information of existing structure
- 4) Current condition of existing structure
- 5) Engineer's/Architect's opinion of the adequacy of the existing structure to support the anticipated loads
- 6) Engineer's/Architect's repair plan, if required, to bring the structure up to the adequacy required to support the anticipated loads.

The Structural Verification Report Form can be found at:

https://library.municode.com/tx/austin/codes/building_criteria_manual?nodeId=S4RECO_4.4.0RESURE_4.4.4STPL_4.4.4.7STVERERE

Reference: Rule of Adoption R161-15.19 Building Criteria Manual, Section 4: Residential Construction

<http://www.austintexas.gov/edims/document.cfm?id=245752>