

AUSTIN POLICE DEPARTMENT

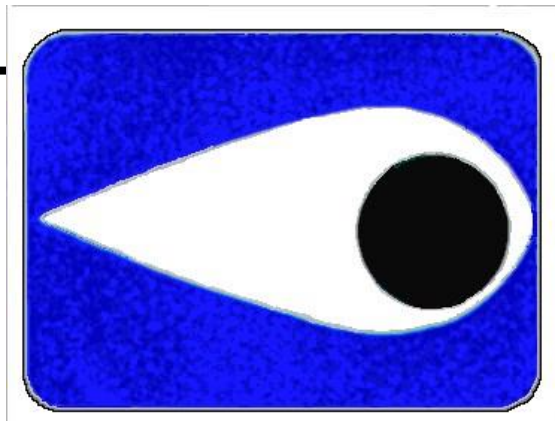

FORMING A NEIGHBORHOOD WATCH PROGRAM



What Is Neighborhood Watch?

- Organization of Established Neighborhood Watch – Second Meeting7 - 8
- Sign Posting Guidelines9
- Appendix A: Family Data Sheet.....10
- Appendix C: Typical Neighborhood Map.....11
- Other Suspicious Activity14 - 17
- Requirements for Reduction in Homeowner Insurance Premiums18 - 19
- Vacation Check-Off List20
- Burglary Prevention Checklist for Homes21 - 22
- Other Security Considerations23
- Reporting and Purpose of Reporting.....24
- Personal/Business Property Inventory List25

WHAT IS NEIGHBORHOOD WATCH?

Crime or the fear of crime provides the impetus for residents to become better informed on how to protect themselves and their property.

Getting back to the old adage of being our "**brother's keepers**", means neighbors watching out for other neighbors. Neighbors are asked to be the eyes and ears in helping the police in apprehending criminals. Crime Watch is not designed to substitute for police protection. Rather it is an extension or supplement in assisting the police in making neighborhoods safer for all residents.

Neighborhood Watch operates under two principles. When neighbors get to know and watch out for each other, they watch out for each other's property as though it was their own. Second, Neighborhood Watch helps to create an identity within the neighborhood, which in turn fosters sense of pride, and belonging for the participants.

The participants make their neighborhood a safer place to live by adopting a more observant and active attitude and, as a result, become more aware of strange cars, persons, or circumstances. This will not take a lot of time and soon will develop into a daily habit of becoming more aware of what is going on in the neighborhood.

ORGANIZING A CRIME WATCH PROGRAM

Crime Watch programs take many forms, but in all cases, organization by blocks is the cornerstone of all neighborhood crime prevention programs. The following are basic guidelines to help establish and maintain Crime Watch for a neighborhood.

- Step 1** Talk with neighbors and friends.
Ask for their participation in a small core group to take the first steps in starting a Crime Watch program.
- Explain the need for and value of a Neighborhood Crime Watch.
- Define the boundaries of the areas to be organized.
- Step 2** Contact your Austin Police Department District Representative Office.
Explain that you would like to start a Neighborhood Crime Watch and ask for help from a district representative.
- Discuss the size and boundaries of the area considered for the program.
- Step 3** Planning the first Neighborhood Meeting:
- Make arrangements to use a convenient meeting place that will accommodate the number of people who might attend. Design a simple flyer or ask your Austin Police District Representative Office for help in developing a flyer to announce the meeting. Recruit volunteers to hand deliver an invitation to every home in the area. **Do not place meeting notices in mailboxes** if they do not have the appropriate postal stamp affixed.
- Your Austin Police District Representative Office will provide specific details as to the content of the first Crime Watch meeting and possible topics for future meetings.

USING THESE GUIDELINES

The Sign Center, Inc. has gathered information and guidelines regarding Neighborhood Watch programs. The following guidelines describe how to organize and operate a Crime Prevention Program, and are offered only as suggestions on how a Neighborhood Watch program might be established. The extent of neighborhood problems and the commitment by neighborhood residents will determine which of the suggestions are adopted. *

Neighborhood Watch programs involve the following primary activities:

Neighbors getting to know each other and working in a program of mutual assistance.

Residents being trained to recognize and report suspicious activities in their neighborhoods.

Implementation of crime prevention programs, such as Neighborhood Watch, Crime Watch, Operation Identification, and others.

*The information in this section was compiled from the following sources:
The Virginia Secretary of Public Safety "Status of Neighborhood Watch in Virginia", Dec. 1, 1983;
San Diego Police Department Crime Prevention Unit "Community Alert Program Guidelines", Sept. 1979.

ORGANIZING A NEIGHBORHOOD WATCH MEETING (Continued)

First Meeting

- B. Follow-up Activity
 - 1. Contact the Austin Police Department District Representative Office to advise them of your plans and invite them to participate in the first formal neighborhood meeting. Allow them at least two-to-four weeks to arrange their schedule.
 - 2. Request a presentation on crime and what residents can do to prevent it.
 - 3. Obtain a instructions from law enforcement (if possible) on how to do the following:
 - A. Obtain reports on crime in the neighborhood.
 - B. Obtain information on crime trends which may affect the neighborhood.
 - 4. If there is a civic association representing the neighborhood, ask the appropriate committee to study the development of the Neighborhood Watch program.
 - 5. Send out notices to all neighbors. Include date, time, location and purpose of meeting.

ORGANIZATION OF ESTABLISHED NEIGHBORHOOD WATCH GROUP

Second Meeting

Follow-up Activity

A. NEIGHBORHOOD WATCH COMMITTEE GUIDELINES

1. The Neighborhood Watch Coordinator and the block/road captains are the most crucial positions. They provide leadership and coordination and serve on the Neighborhood Watch Committee, which has the following responsibilities:
 - A. To maintain and expand the program to include as many residents as possible.
 - B. To set forth objectives and strategies in cooperation with law enforcement that will make the neighborhood safer.
 - C. To plan and implement programs that will be beneficial and appropriate for the neighborhood.
 - D. To assess the success of the program and provide feedback to residents and law enforcement.

B. NEIGHBORHOOD WATCH COORDINATOR GUIDELINES

(Alternative for a Crime Prevention Officer, when one is not available from law enforcement agency).

1. Serves as liaison between the law enforcement agency and the neighborhood.
2. Seeks resources and materials and makes them available to block captains.
3. Passes information obtained from law enforcement to block captains.
4. Passes information from block captains to law enforcement; i.e., suspicious vehicles in neighborhood, problems and concerns.
5. Maintains a master list of Watch members.
6. Arranges Neighborhood Crime Prevention programs in conjunction with law enforcement.
7. Obtains signs proclaiming that the neighborhood has a Watch Program.
8. Provides reports to the civic association, if such exists.
9. Supervises the activities of the block captains.
10. Establishes subcommittees to develop specific crime prevention projects; i.e., Operation Identification, Block Parents, etc.

ORGANIZATION OF ESTABLISHED NEIGHBORHOOD WATCH GROUP

Second Meeting

Follow-up Activity – (Con't)

EVERY DAY

1. Be observant. Keep watch on neighbors, homes and report suspicious activities to neighbors or law enforcement when appropriate.
2. Write down and report license numbers and description of suspicious looking persons and vehicles in the neighborhood.
3. Educate your children in crime prevention and instill respect for law enforcement.
4. Do not try to make arrests. Being a good witness is more important. Get all necessary information and phone your Police or Sheriff Department.

E. ACTIVITIES AND TOOLS

1. Patrols
 - A. Should only be organized after discussion with local law enforcement.
 - B. Can be accomplished by foot, bicycle or motor vehicle.
 - C. Magnetic car signs are available for designating vehicle patrol. (See Neighborhood Watch or Crime Watch program brochures for more detailed descriptions.
 - D. Citizen band radios or walkie-talkies can be used to speed transmission of suspicious activity reports.
 - E. Should only observe and report and take no direct action.
2. Telephone Tree
 - A. Each individual in the Watch group is assigned to contact a specific number of other neighbors to pass on general information.
 - B. Vital information is required during and after suspicious circumstances or emergencies and can be communicated to others within the system.
 - C. Each resident must provide his or her block/road captain with sufficient information about the household to make the system effective (see Appendix A)

SIGN POSTING GUIDELINES

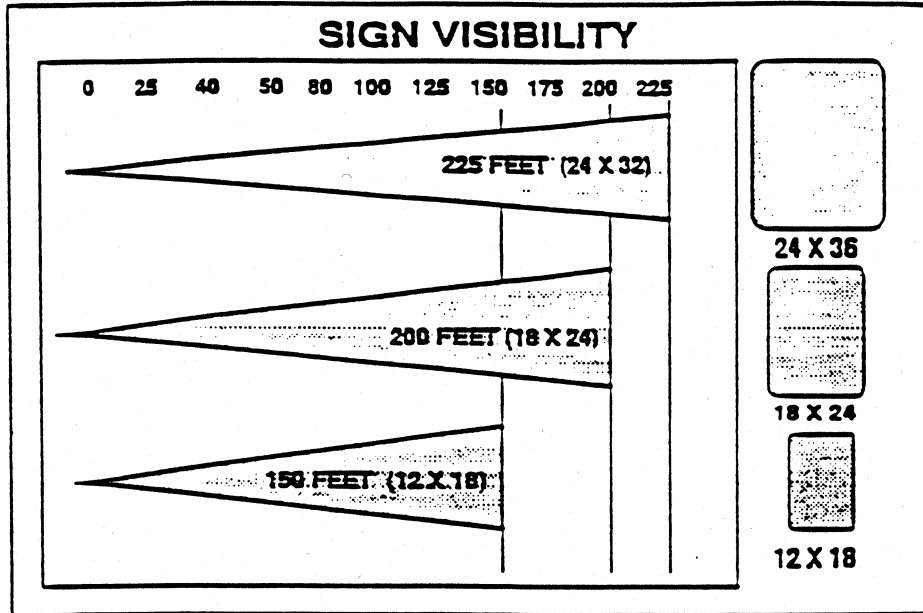

ALL DISTANCES ARE APPROXIMATE AND INTENDED ONLY AS A GUIDE

- | | |
|----------------|---|
| 24 x 32 | SIGN IS READABLE UP TO 75-80 FEET – LOGO IS VISIBLE UP TO 175-200 FEET.
Recommended for defining boundaries. Placed at entrance points of community or mobile home park, or parking areas of apartment and condo complexes. |
| 18 X 24 | SIGN IS READABLE UP TO 40-50 FEET – LOGO IS VISIBLE UP TO 125-150 FEET.
Recommended for neighborhood streets and business district. |
| 12 X 18 | SIGN IS READABLE UP TO 25-40 FEET – LOGO IS VISIBLE UP TO 75-100 FEET.
Recommended for use within the neighborhood. |
| 12 X 12 | PLASTIC YARD SIGN
Recommended for gates, garages, fence posts; should be visible from the street. |
| 5 X 5 | PLASTIC GATE OR ENTRY SIGN
Use near entrance to home; visible only close-up. |

Individual municipalities and counties may have ordinances regarding the posting of signs. The departments of City Planning or Public Works may be a reference source for specific restrictions concerning your area.

Signs are not intended for posting on utility poles, telephone poles or any other standard that a repairperson may have to climb. Posting on traffic sign poles is usually prohibited.

The Sign Center, Inc. has sign clamps and pole brackets available with tamperproof screws. Exposed bolts and threads should be damaged after installation to prevent removal by vandals.

APPENDIX A: Family Data Sheet

NEIGHBORHOOD WATCH FAMILY DATA SHEET (To be maintained by NEIGHBORHOOD WATCH Coordinator)

HOME ADDRESS: _____ HOME TELEPHONE: _____

FAMILY NAME: _____ TOTAL RESIDENTS: _____

MAN OF HOUSEHOLD: _____ WORK TELEPHONE: _____

WOMAN OF HOUSEHOLD: _____ WORK TELEPHONE: _____

TOTAL NUMBER OF CHILDREN IN HOUSEHOLD: _____ LIST NAMES AND AGES BELOW:

NAME: _____	AGE: _____	NAME: _____	AGE: _____
NAME: _____	AGE: _____	NAME: _____	AGE: _____
NAME: _____	AGE: _____	NAME: _____	AGE: _____

NAMES OF OTHER RESIDENTS: _____

IN CASE OF EMERGENCY CONTACT:

NAME: _____ HOME TELEPHONE: _____
ADDRESS: _____ WORK TELEPHONE: _____

FAMILY VEHICLES:

NO. 1	MAKE: _____	STYLE: _____	COLOR: _____	LICENSE #:
NO. 2	MAKE: _____	STYLE: _____	COLOR: _____	LICENSE #:
NO. 3	MAKE: _____	STYLE: _____	COLOR: _____	LICENSE #:

LIST ANY SPECIAL FAMILY HEALTH OR MEDICAL INFORMATION: _____

LIST ANY SPECIAL EMERGENCY MEDICAL CARE TRAINING OR SKILLS: _____

LIST ANY OTHER PERTINENT – IMPORTANT INFORMATION: _____

APPENDIX B: Neighborhood Map

Typical Neighborhood Map -Prepared by Block Captain.

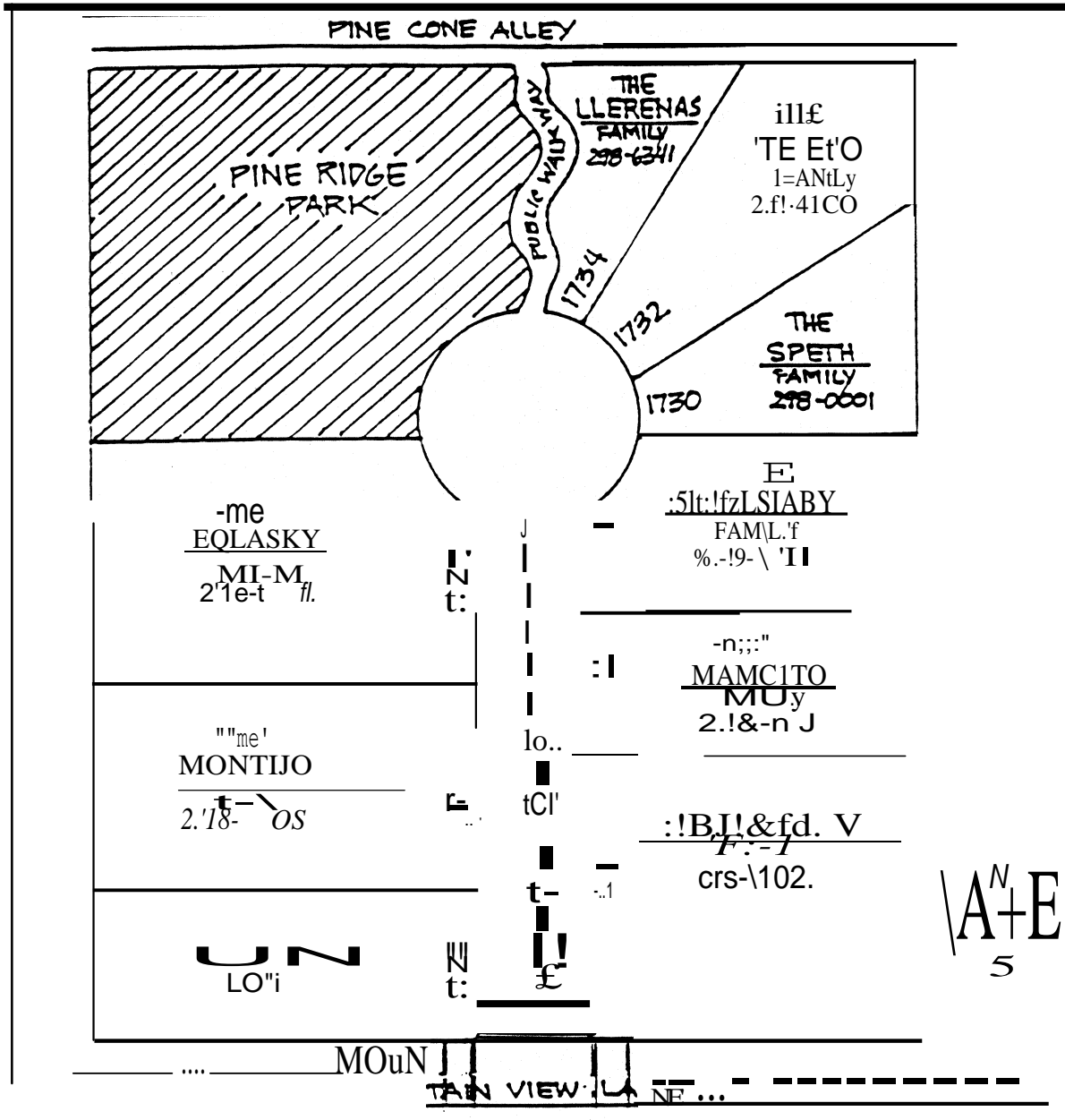

CRIME WATCH PARTICIPANT GUIDELINES

Participation in Crime Watch is not something that takes a lot of time. It does require each person to adopt a more observant and active attitude on a daily basis.

As a result, neighbors will get to know each other better and will become more aware of strange cars, persons or circumstances that might require calling the police.

What participants do to make their homes more secure and how alert they become is entirely up to them. The more prepared individuals are, the more effective will be the weapon against crime.

- Get to know your neighbors. Know their names and be able to identify them and their vehicles by sight.
- Maintain a map of the immediate neighborhood with names and addresses.
- Mark all property for identification using the "Operation Identification" program.
- Be observant and watch over neighbors' homes, especially when they are not at home or out of town.
- Write down license numbers and descriptions of suspicious-looking vehicles and persons in the neighborhood and report them to the police immediately.
- Report information that may be helpful in solving a crime to the police.
- Educate children in crime prevention and teach respect and friendship for law enforcement and police officials.

SUSPICIOUS ACTIVITY CONCERNING PERSONS

CIRCUMSTANCE	POSSIBLE CRIME
Going door-to-door in a residential area, especially If one or more persons goes to the rear of the Residence.	Possible burglary suspects or trespassers.
Waiting or loitering in front of a house or business, If business is closed or house unoccupied.	Possible burglary suspects.
Forcing entrance, or entering your neighbor's house, When it is unoccupied.	Possible burglary, theft or trespassing.
Person running, especially if something of value is being carried.	Possible suspect fleeing the scene of a crime.
Person carrying property that is not wrapped, at an unusual hour.	Possible suspect fleeing the scene of a burglary or robbery.
Much human traffic to and from a certain residence if it occurs on a daily or regular basis.	Possible drug, vice or a fence operation.
Person screaming.	Possible rape or assault.
Person loitering around cars or going car-to-car peering into them, especially in parking lots or on streets.	Possible car thief.
Persons loitering around schools, parks, or secluded areas.	Possible sex offenders.
Person offering items for sale at very low price.	Possibly trying to sell stolen property.
"Delivery Man" with a wrong address or one who asks if someone else lives there.	Possible burglary suspect.

OTHER SUSPICIOUS ACTIVITY

CIRCUMSTANCE	POSSIBLE CRIME
Continuous repair operations at a non-business location.	Possible stolen property being altered.
Open or broken doors and windows at a closed business or unoccupied residence.	Possible burglary in progress, completed burglary, or vandalism.
Unusual noises such as gunshots, screaming, or dogs barking continuously.	Possible burglary, assault, rape, etc.
Sound of breaking glass.	Possible burglary or vandalism.
A person exhibiting unusual mental or physical symptoms.	Person may be injured, under the influence of drugs, or otherwise needing medical attention.
Property in homes, garage, or storage areas is suspicious if accumulations are large, or items are in good condition but not in use.	Possible stolen property.

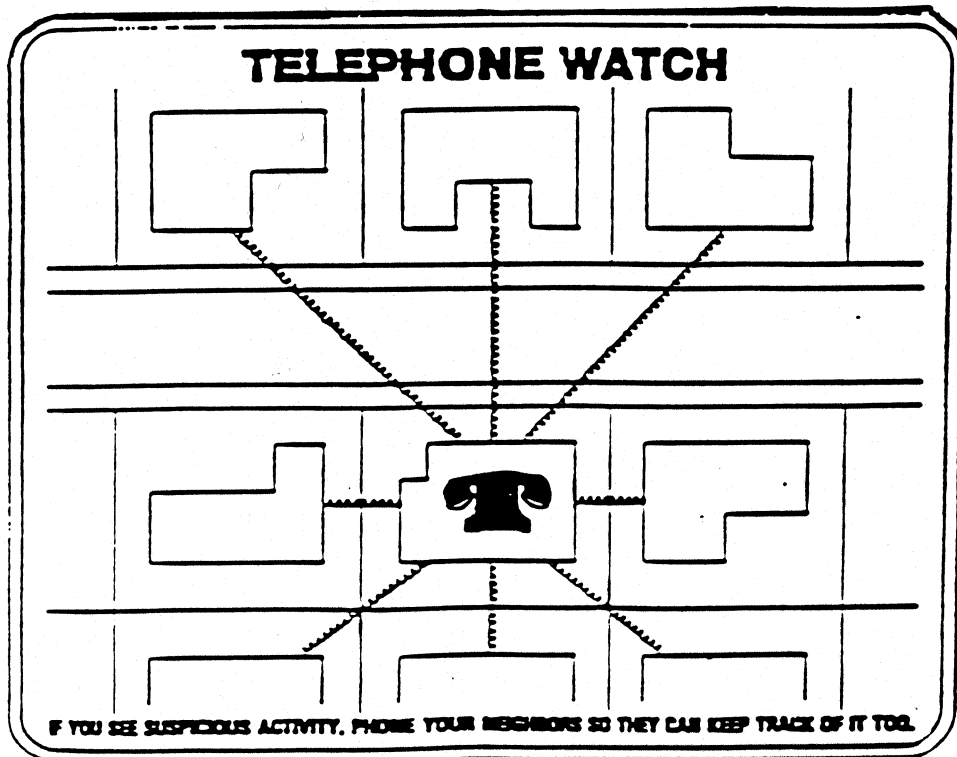

Do you have a privacy fence that obstructs your neighbors' view of your backyard? Are your fence crossrails on the outside presenting a stepladder-type entry into your backyard? What about your gate - is it secured?

Privacy fencing is a disadvantage to home security since it provides concealment. Other forms of fencing would eliminate this disadvantage, but here are some methods to offset this problem:

1. Remove every other slat along the alley side of the fence to allow greater visibility.
2. Plant a hostile-type plant to cover the outside of the fence, (i.e., climbing roses with large thorns or pyracantha).
3. Padlock your gate so that entry is made more difficult (for more information, see section on padlocks).

If your fence has not been built, have the installer place the crossrails on the inside of the fence.

NOW THAT WE'VE WALKED AROUND THE OUTSIDE OF YOUR HOUSE, LET'S GET READY TO GO INSIDE AND LOOK FOR QUESTIONS AND ANSWERS

Let's go to the front door – as I walk up to the door, can you see me from the inside? Do you know who is outside before you open it?

A good idea here is to install a wide-angle viewer (peephole) in the door. This will let you know who is on the outside before the door is open. (A 190-degree view is recommended).

Now, how about that door? Is it solid core? Is it metal? Is it cracked or splitting? How thick is it?

Not only your front door, but also all of your exterior doors and the door between your house and the garage should be of solid core construction or heavy gauge metal with a minimum thickness of 1 3/8 inches. A thinner door may give if kicked. And if your door is the panel-type, make sure joints haven't come unglued and panels are not split or rotten.

While we are looking at the door, let's have a look at the strike plate on the doorframe. Is yours of lightweight metal installed with short wood screws?

Other types of doors in the home must also be adequately secured. Sliding glass doors are particularly vulnerable to attacks by burglars.

Secure sliding doors to keep them from sliding or being pried up and out of the track by Pinning: -- Drill a slightly downward sloping hole through top portion of the sliding door frame. Insert a pin as illustrated. This will help secure the door from being pried open. To keep it from being lifted out of its track you can place two or three screws in the top track that allow just enough room for the door to open and close but will not allow the door to be lifted.

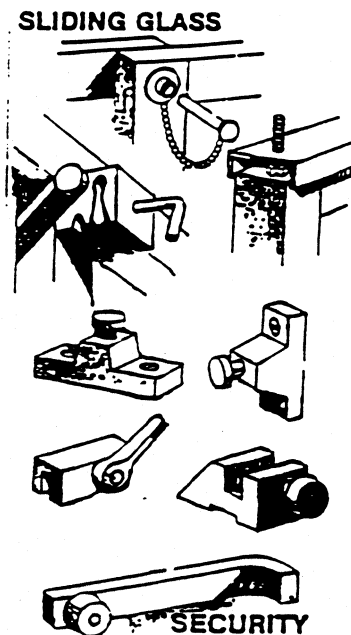
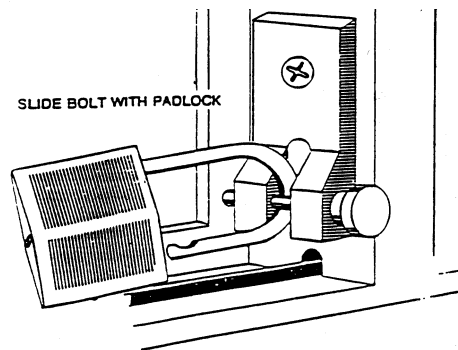
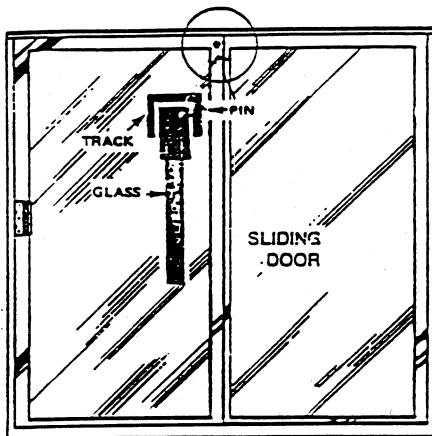

Now that we've been through most of your house, let's go into your garage and have a look around. We've already discussed the point that the door from your house into your garage should be secured with a deadbolt lock and should be of the same construction as exterior doors. Now that we're in the garage, how about the garage door itself? Is it deteriorating and easily bypassed? Does it have windows? How about a garage door opener? Does the cord release for your garage door opener hang by the door when your door is closed? Most garage doors, due to their construction, are difficult to secure. Several recommendations can be made, however:

Keep garage doors closed and locked at all times.

Remove any knobs or rings from an automatic garage door release. With these in place, an intruder can place a coat hanger through the top of the garage door and pull the cord (or break a window and reach in), releasing the garage door from the track.

Cover the garage window to prevent persons from viewing inside. It makes it more difficult for someone to determine whether you are home or not. Mirrored film on your windows allows you to see out but doesn't allow them to see in.

While on vacation, place a padlock through the track. If your door is deteriorating or you are considering replacement, a windowless garage metal door provides the most security.

And while we're in the garage, let's look up. Do you have an attic access in the garage? If your attic access is in the garage and another inside your residence, the garage attic access should be secured. This can be accomplished by adding a case-hardened hinging hasp and padlock. This prevents an intruder from going through the attic, if he does get into the garage.

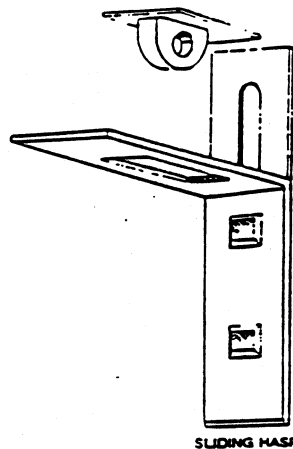

NOTE: WE HAVE ATTACHED A SECURITY CHECKLIST AT THE END OF THIS MANUAL FOR YOU TO EVALUATE YOUR HOME SECURITY.

REQUIREMENTS FOR REDUCTION IN HOMEOWNER INSURANCE PREMIUMS

The 67th Legislature of the State of Texas has provided for a **5-15%** reduction in Homeowner Insurance Premiums provided homes meet specific requirements.

By appointment, an A.P.D. Police Officer who is certified by the Texas Crime Prevention Institute as an Inspector will come to your residence to complete a security survey and make recommendations on how to improve your current security and ascertain whether or not your home qualifies for a Homeowners Insurance reduction.

HOME PREMIUM REDUCTIONS (minimum required for 5% reduction)

A person's property qualifies for a Homeowner Insurance Premium Reduction if the property meets the following specifications:

- (1) Exterior doors must be solid core doors that are 1 3/8 inches thick and must be secured by deadbolt locks; a deadbolt lock must lock with a minimum bolt throw of 1 inch that penetrates a metal strike plate;
- (2) Metal doors must be secured by deadbolt locks;
- (3) Double doors must be solid core doors that are 1 3/8 inches thick and must be secured by deadbolts; the inactive door must be secured by header and threshold bolts that penetrate metal strike plates, and in the case of glass located within 40 inches of header and threshold bolts, the bolts must be flush-mounted in the edge of the door;
- (4) Sliding glass doors must be secured by secondary locking devices to prevent lifting or sliding;
- (5) Garage doors must be equipped with key operated devices; and,
- (6) Windows must be secured by auxiliary locking devices.

ALARM REDUCTIONS (minimum required for additional 15% reduction)

Property is equipped with an electronic burglar alarm that meets the following requirements:

- (1) All exterior structure openings are contacted;
- (2) the system includes an interior and exterior siren;

- (3) all equipment is U.L. approved and is monitored by a U.L.-approved central station; and sales, service installation, and monitoring of the system are done in compliance with the Private Investigation and Private Security Agencies Act (Article 4413 (22bb), Vernon's Texas Civil Statutes).

The requirements in number three (3) must be in writing from the alarm company.

A home must meet these specifications prior to inspection and prior to any Premium Reduction Certificate being issued.

Premium Reduction Certificates are valid for a period of three (3) years. Certificates may be renewed for an additional three-year period at the request of the homeowner.

To schedule your FREE Home Survey, call the Austin Police Department District Representative Unit for your area:

Region 1 (CW/NC/DT) (512) 974-6949
Region 2 (NW/NE) (512) 974-5598
Region 3 (CE/SC) (512) 974-8578
Region 4 (SE/SW) (512) 974-8241

NOTE: Please allow two – four weeks advance notice while scheduling.

VACATION CHECK-OFF LIST

1. Lock all doors, including the garage door.
2. Lock all windows, including basement and garage windows.
3. Cancel all deliveries such as newspaper, food services, etc.
4. Have mail and newspapers picked up by a neighbor if possible.
5. Have someone pick up handbills and throw-aways.
6. Never leave a note on the door that may indicate your absence.
7. Arrange to have the lawn cut or the snow shoveled.
8. Adjust blinds to make the house/apartment appear to be occupied.
9. Place a light or two on automatic timers.
10. Remove ladders from sight and secure them in locked places.
11. Don't hide keys under doormats or flowerpots or in similar places.
12. Secure items such as jewelry, furs, cameras, credit cards, and checkbooks _____
13. Arrange for a house-sitter, someone to live in your house while you are away, if possible. _____
14. Arrange for a neighbor to keep an eye on your property and to report anything suspicious to police. _____
15. Let a neighbor know where you can be reached in case of an emergency. _____
16. Arrange with a neighbor to leave his or her car parked in your driveway or in front of your house or apartment. _____
17. Leave a radio on just inside your doorway. _____
18. Lower the tone on your telephone. _____
19. Ask neighbors not to tell strangers such as salespersons and repair persons of your absence. _____
20. Do not advertise your absence in the local social notices. _____
21. Notify your local law-enforcement agency of your absence. _____

BURGLARY PREVENTION CHECKLIST FOR HOMES

This checklist was designed to help you make a security survey of your own home.

The first purpose of home security inspection is to identify features in your home or daily routines of your family that might make your home an easy target for a burglar.

The security inspection should begin at your front door, and include an inspection of all your doors and windows, locks, lights and landscaping. Each question on the checklist that you answer with an "X" or checkmark in the second column indicates a security weakness or hazard that requires your attention.

DOORS	Yes	No
1. Are all outside doors in the house of metal or solid wood construction?	_____	_____
2. Are all exterior doors equipped with single cylinder deadbolt locks?	_____	_____
4. Are door frames strong enough and tight enough to prevent forcing or spreading?	_____	_____
5. Are all door locks adequate and in good repair?	_____	_____
6. Are all exterior doors equipped with heavy-duty strike plates with a minimum of 3" screws to secure it?	_____	_____
7. Has the hole in the doorjamb, surrounded by the strike plate, been drilled at least 1" deep?	_____	_____
8. Can the locking mechanism be reached through a mail slot, delivery port or pet entrance at doorway?	_____	_____
9. Is there a screen or storm door with an adequate lock?	_____	_____
10. Are all entrances lighted with at least a 40-watt light?	_____	_____
11. Are outside lights controlled by timers or photo-electric cells, for automatic operation?	_____	_____
12. Can front entrance be observed from street or public area?	_____	_____
13. Do you know everyone who has a key to your residence?	_____	_____
14. Have you had your locks re-keyed?	_____	_____
15. Does porch or landscaping offer concealment from view from street or public area?.	_____	_____
16. If there is a sliding glass door, is the sliding panel secured from being lifted out of track?.	_____	_____

17. Is "charley-bar" or key operated auxiliary lock used on sliding glass doors? _____

BASEMENTS

18. Are all entrances to living quarters from garage, porch, balcony and basement of metal or solid wood construction? _____

19. Does door from basement to living quarters have an adequate lock operated from living quarters side? _____

20. Is there a door from outside to the basement? _____

21. If so, is that door adequately secure for an exterior door? _____

22. Is outside basement entrance lighted by exterior light of at least 40 watts? _____

23. Is outside basement door concealed from street or neighbors? _____

24. Are all basement windows adequately secured against entrance? _____

WINDOWS

25. Do all windows have adequate locks in operating condition? _____

26. Do windows have screens or storm windows that lock from inside? _____

27. Do the windows opening to hazardous areas or offering increased risk of burglary have additional security? _____

28. Do windows that open to hazardous areas have security screens, grills or bars that open from the inside? _____

OTHER SECURITY CONSIDERATIONS:

Safe practices

Do you plan so that you do not need to "hide" a key under the doormat?

Do you keep as much cash as possible, other valuables and a home inventory in a bank?

Have you engraved all of your property with your driver's license number and included the state?

Do you have a list of the serial numbers of your watches, cameras, typewriters, TV's, stereos, and all items that have serial numbers?

Do you have a description of other valuable property that does not have a number?

Do you avoid unnecessary display or publicity of your valuables?

Have you told your family what to do if they discover a burglar breaking in or already in the house?

Have you told your family to leave the house undisturbed and call the police if they discover a burglary has been committed?

This checklist was designed to help you go through your home and check to see that you are not inviting a burglary by having an "open house." The checklist covers the common areas of weakness in residential security.

To keep your guard, take a critical look at your home security every three to four months. Don't become lax – CRIME PREVENTION IS A CONTINUOUS PROCESS.

Secondary Barrier – Security Closet

If you have valuable items such as silverware or jewels, consider a secondary barrier. Install a solid core wood door with a 1" deadbolt on a closet. Store your valuables in that area. Also, be sure to pin the hinges. If you use your master bedroom closet it can become a momentary hiding place to flee in the event of an intruder. It would be even more effective if a cordless telephone were inside the closet to allow calling 911 and alerting the police to the intruder. Keep coin and stamp collections in a safe deposit box.

REPORTING AND PURPOSE OF REPORTING

The purpose for reporting suspicious activity to the police is to stop the criminal activity, increase police presence in your neighborhood and give a true perspective of crime. Making a report will enhance the possibility of getting your property returned.

Keep police emergency numbers close by when reporting suspicious activity or an emergency. Anything that seems slightly "out of place" or does not look right could be criminal activity. **CALL THE POLICE IMMEDIATELY ABOUT ALL SUSPICIOUS ACTIVITY.** Do not worry about "bothering" the police or being embarrassed if your suspicions prove to be unfounded. Think ahead about what could happen if you don't act. Give the police or the telephone clerk:

The reason for the call.

The location of the activity.

The description of the suspect and any vehicle involved.

If the crime is in progress, give the circumstances and possible crime being committed.

WHEN IN DOUBT, CALL IT IN

Under **no** circumstances attempt to apprehend a person committing a crime or try to investigate suspicious activity. The police want your information – not your action.

The police department would rather investigate than be called when it is too late. Your call could save a life, prevent an injury or stop a criminal act. **BE ALERT.**

Not every stranger who comes into your neighborhood is a criminal, by any means. There are many door-to-door salesmen, repairmen, and servicemen moving around our neighborhood all the time. But criminals do take advantage of this by pretending to be legitimate workmen.

