

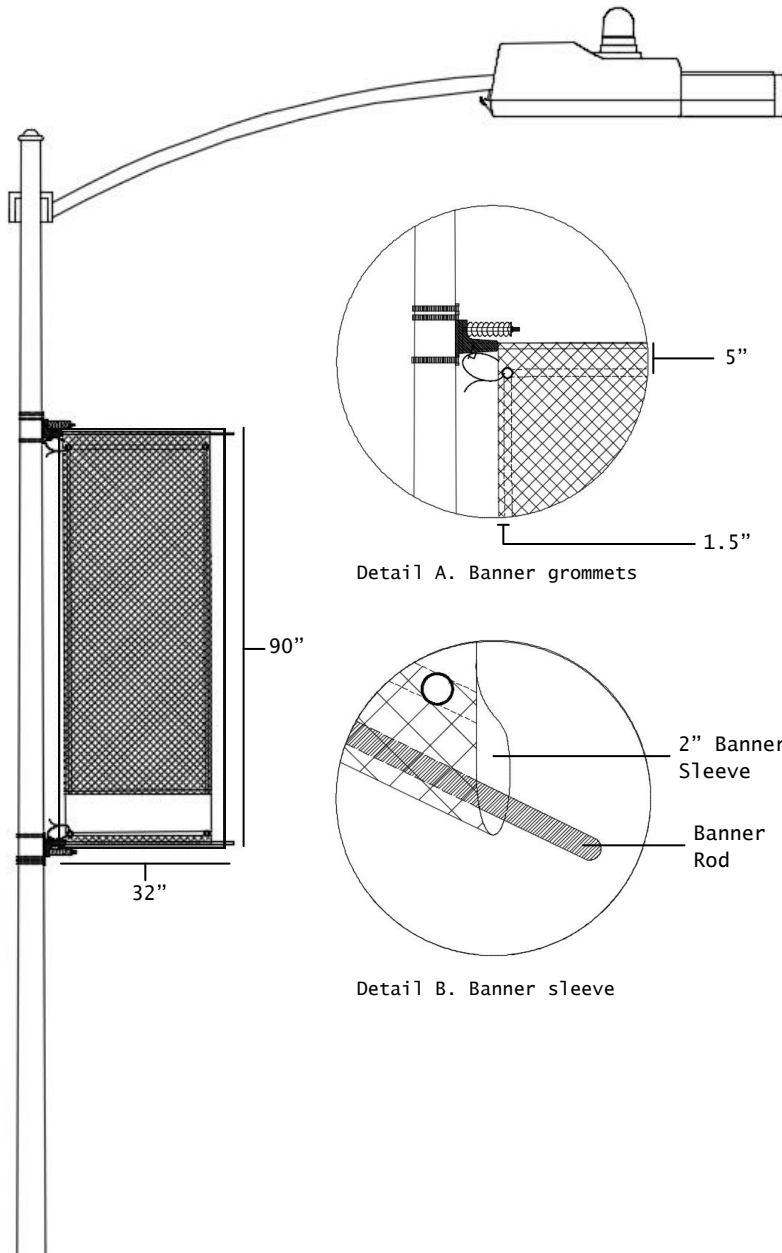

TRANSPORTATION

# Lamppost Banner Technical Specifications & Design Requirements

[ATXBanners.org](http://ATXBanners.org)



Detail A. Banner grommets

Detail B. Banner sleeve

## TECHNICAL SPECIFICATIONS

1. Banners shall be **32" x 90"** in size.
2. Banners shall be made of vinyl resistant to ultraviolet rays, mold and mildew.
3. Each banner shall have four (4) brass grommets, two on each side (see Detail A).
4. Each banner shall have two (2) double-stitched reinforced sleeves on top and bottom. Sleeves for banner arms must be 2" wide (see Detail B).
5. All banners must be printed on both sides.

## DESIGN REQUIREMENTS

1. Banner design should include no more than 4-6 elements. These typically include:
  - Event name with a "call to action"
  - Sponsor name
  - Date and location
  - A single graphic image (a URL may be included)
2. Headline lettering shall be no less than 5" high.
3. Subhead lettering (e.g. event date and location) shall be no less than 4" high. If the event will reoccur, consider omitting dates so that banners can be reused.
4. Image resolution shall be no less than 300 dpi (dots per inch).
5. Sponsor name/logo, if used, can appear only on the lower 12" of banner. Sponsor logos can vary by banner.

## DESIGN TIPS

- \* Make each element as **BOLD** and **vivid** as possible.
- \* Use a sans serif font, as they are easier to read from a distance. Refrain from using more than two font styles on a banner, unless part of a logo.
- \* Use background colors other than white, beige and pale blue for best visibility.
- \* Use high-contrast colors for best readability.
- \* Where poles are double-bracketed, design should treat the two banners as a single integrated canvas.

**Banners not meeting the specifications will be rejected.  
Refunds are not granted for banners that cannot be installed because of incorrect specifications.**

All banner designs must be approved before a reservation is finalized and at least **30 days prior to installation**.